

NOTES:

(NI) 1. TO INSPECT ASSEMBLY, FOLLOW FIRST ARTICLE AND IN PROCESS INSPECTION SHEET.

2. APPLY LOCTITE 680 IF NYLON PATCH IS MISSING.

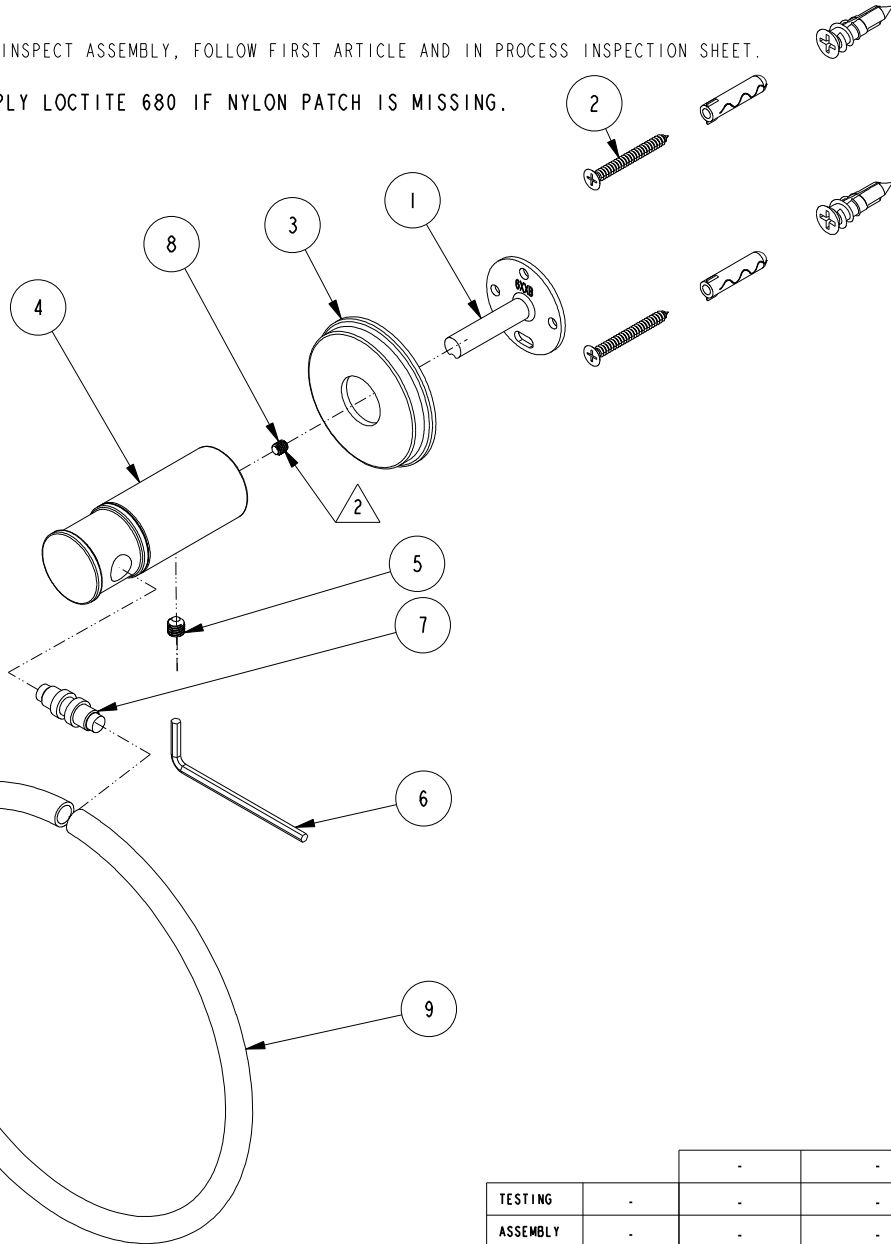

BILL OF MATERIAL (CURRENT LEVEL)

ITEM	PT/ASSY	DESCRIPTION	TYPE	QTY.
1	6XXB	MOUNTING BRACKET	PART	1
2	1-206	HARDWARE PACK	ASSEMBLY	1
3	20-433	ESCUTCHEON ASM	ASSEMBLY	1
4	13176	POST, TOWEL RING	PART	1
5	92031	SCRW, M6 X 1 X 6 SKT HD CUP PT W/ SELF LOC SS	PART	1
6	10615	HEX KEY, 3MM ALLOY STEEL	PART	1
7	40467	TOWEL RING COUPLER	PART	1
8	92001	SCRW, 8-32 X 3/16 SKT HD FLT PT SS	PART	1
9	10127	TOWEL RING	PART	1

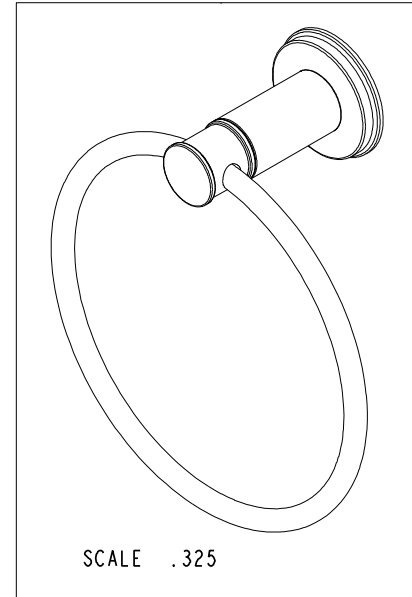

ZONE	REV	DESCRIPTION	DATE	APPROVED
-	B	EN-4256	09/18/20	J.M.
-	A	EN-4206	07/10/20	J.M.
-	-	EN-3852	05/16/19	J.M.

COPYRIGHT 2005 BRASSTECH, INC. THESE DRAWINGS AND THE DESIGNS DEPICTED HEREIN ARE THE PROPRIETARY PROPERTY OF BRASSTECH. ANY USE OR REPRODUCTION IS SUBJECT TO THE EXPRESS APPROVAL OF BRASSTECH. UNAUTHORIZED USE IS STRICTLY PROHIBITED. ALL RIGHTS RESERVED.

TESTING	-	-	-
ASSEMBLY	-	-	-
PLATING	-	-	-
POLISHING	-	NEXT ASSY	USED ON
MACHINING	-	APPLICATION	
TOOLING FIXTURE #	REMOVE ALL BURRS AND SHARP EDGES		

UNITS ARE: INCHES [MM]		
TOLERANCES ARE:		
FRACTIONS	DECIMALS	ANGLES
±1/16"	.X ±.1 [2.5]	±1°
	.XX ±.06 [1.5]	
(X.XXX) DENOTES CRITICAL DIMS. ALL THREADS ARE CRITICAL		
DRAWN	JIMSON	05/16/19
CHECKED	J.M.	05/16/19
APPROVED	J.M.	05/16/19

BRASSTECH		2001 CARNEGIE AVE. SANTA ANA, CA 92705 (949) 417-5207	
INCORPORATED			
TOWEL RING			
DWG NO.	3270-1410		REV B
SCALE	.375	REF. -	SHEET 1 OF 2

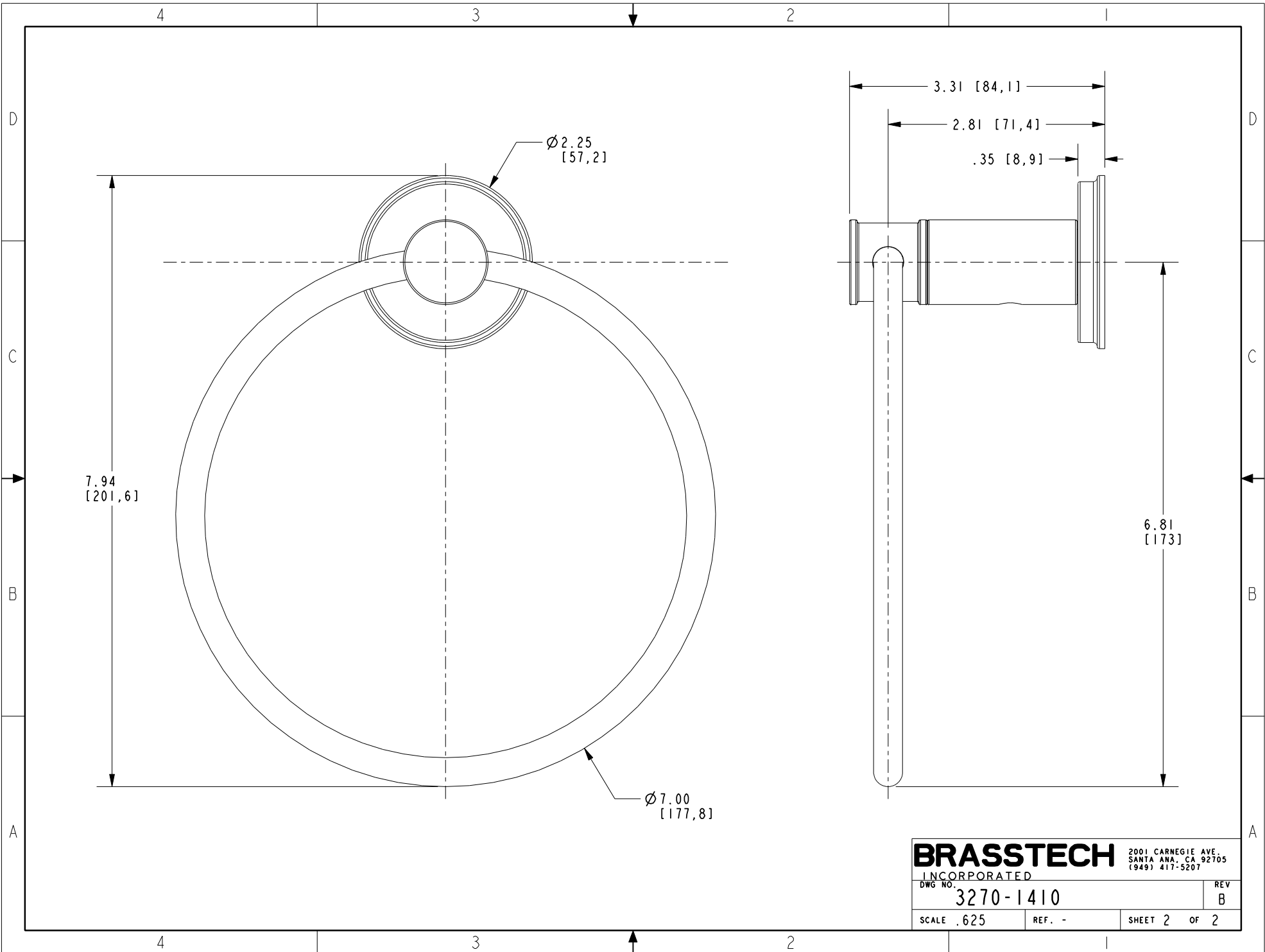

BRASSTECH 2001 CARNEGIE AVE.
 INCORPORATED SANTA ANA, CA 92705
 (949) 417-5207

DWG NO.	3270-1410	REV	B
SCALE	.625	REF.	-
SHEET 2		OF 2	